

X-COUNTRY

TOYOTA LC79 DUAL + SINGLE CAB RAZOR FITMENT

- (A) Read through instructions completely and ensure you understand each step before proceeding
(B) Check the contents of the kit before fitment and report any discrepancies
(C) Pass instructions onto the customer at the completion of the fitment

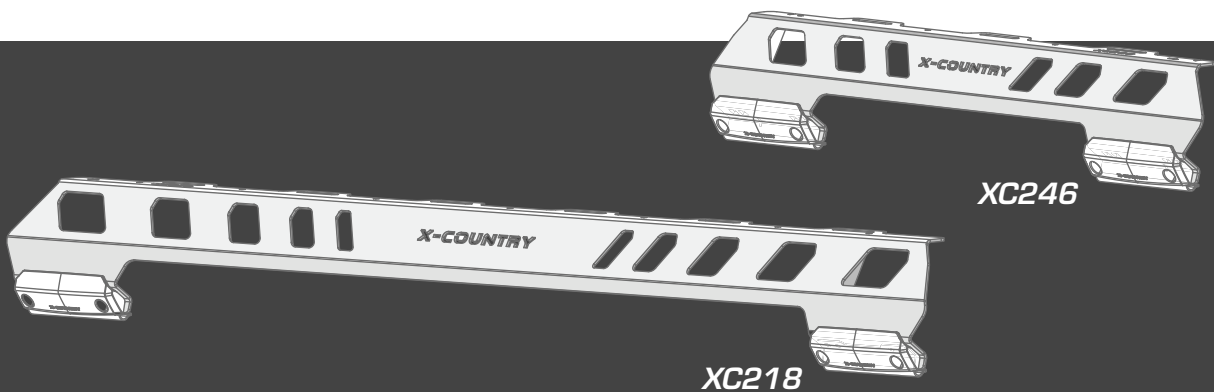

Assembly time: 25min

IMPORTANT

LOAD RECOMMENDATIONS

- *Ensure the load is evenly distributed on the roof. An uneven load can have adverse effects on the handling of the vehicle and the performance of the roof rack. Anytime a load is on the roof, the driver must adjust their driving style and act more cautiously.*
- *Routinely check the roof rack attachment points and ensure they are secure by checking torque, looking for any movement and damage to parts.*
- *Check tie down straps. Ensure they are tensioned securely. Ensure they are positioned correctly over the load. Ensure they are free from damage and 100% operational.*
- *Do not use any automatic car wash service.*

CARRYING CAPACITY

- *Check the vehicle owners handbook for your vehicles maximum carrying capacity. This capacity must then be evenly distributed on the rack.*
- *The actual load on the vehicle roof = weight of cargo + weight of roof rack system*

WARNING

- *Read through the fitting instructions completely before installation. Install as described and do not use any other mounting.*
- *It is advisable to have assistance when lifting heavy components onto the roof area of a vehicle.*
- *Do not repair or modify this part in any way. Repairs or modifications may effect the operation of the part and can result in a non-compliance with vehicle safety requirements.*
- *If damage or concerns are identified that may interfere with the installation, or affect the function or safety of the vehicle, inform the customer prior to proceeding with the install.*
- *Torque settings.*
- *Unless otherwise stated.*

TORQUE SETTINGS

M6 = 4-5Nm

M8 = 8-12Nm

M10 = 18-22Nm

WARRANTY INFORMATION

All items are covered by a 5 year warranty.

If a defect appears in the system before the end of the warranty period and X-Country finds that the defect is in materials or workmanship, X-Country will, in its sole discretion either;

- 1. Repair the system of the defective component of the system free of charge*
- 2. Replace the system or the defective component of the system, or*
- 3. Refund the purchase price of the system to the original purchaser.*

X-Country reserves the right to replace defective products or components with products of components of similar quality, grade and composition, where an identical product or component is not available. Goods presented for repair may be replaced by refurbished goods of the same type rather than being repaired. Refurbished parts may be used to repair goods.

The 5 year warranty does not apply where

The system is not installed in accordance with the fitting instructions

The system is not used as intended or designed

Any part of the system is used with other products or components not intended to be used in conjunction with the system.

The system has been on-sold or assigned by the original purchaser

The system has been modified or repaired by someone other than X-Country or its authorised repairers

X-Country cannot establish any fault after inspection of the returned product

The system has been subject to abnormal conditions, including fire, water, humidity, pressure, stress

The defect in the system, has arisen due to abuse, misuse, neglect or accident

The defect in the system has arisen due to unlawful or unusual use of the vehicle

The defect in the system has arisen due to the purchaser's failure to properly assemble, install, fit, maintain or use the system in accordance with the instructions.

This warranty does not cover wear and tear. Warranty claims are made by contacting X-Country directly or through the place of purchase. All claims must be accompanied by the proof of purchase (receipt), images and a description of the concern. Emails to sales@x-country.com.au

PARTS LIST

HARDWARE

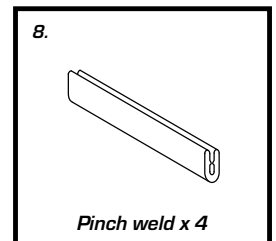
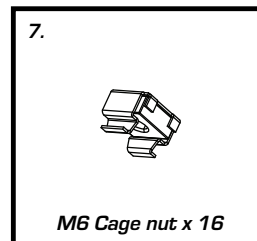
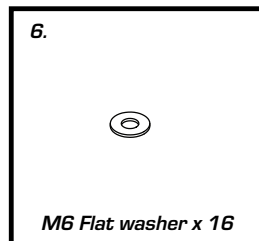
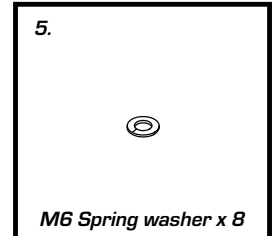
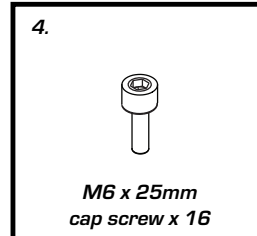
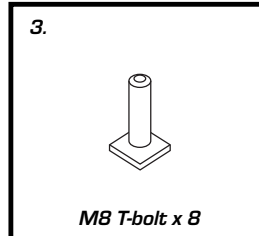
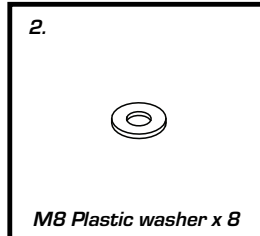
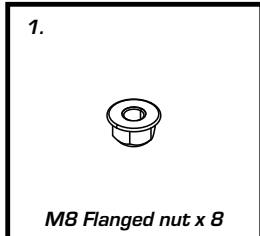

PARTS

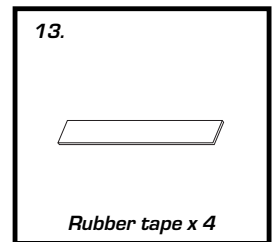
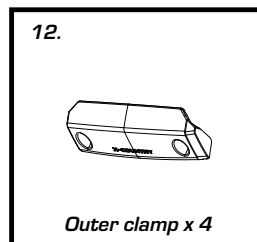
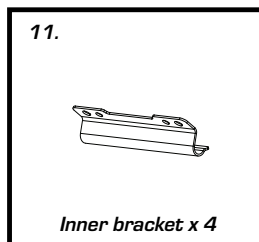
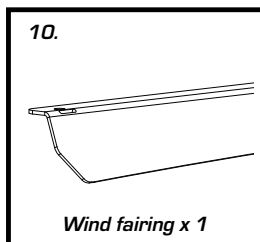
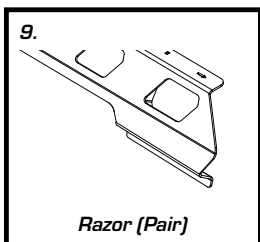

TOOLS REQUIRED

- 6mm allen key
- Socket wrench and set

Note: Summit Platform kit as separate

INSTALLATION

1.

Fit pinch weld to Razors as shown.

*Note: Following steps show Dual Cab (XC218) Razor.
Similar fitment is undertaken for Single Cab (XC245).*

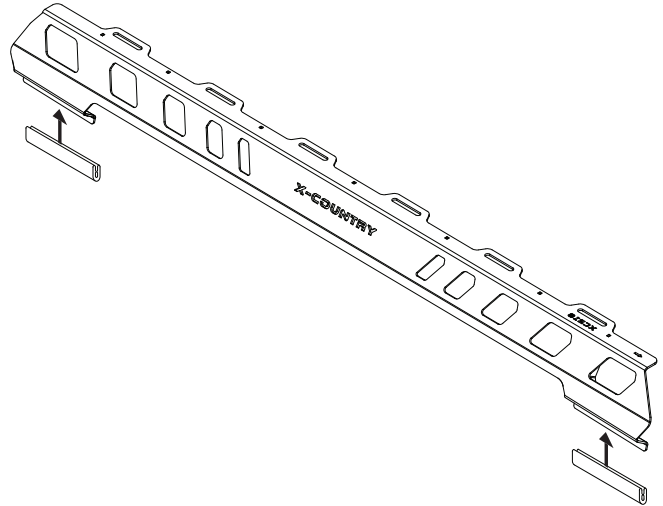

2.

Insert cage nuts into the square holes in the Razor bases.

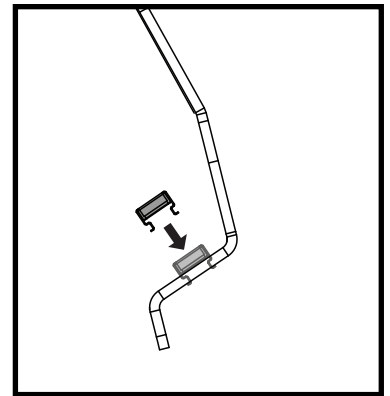
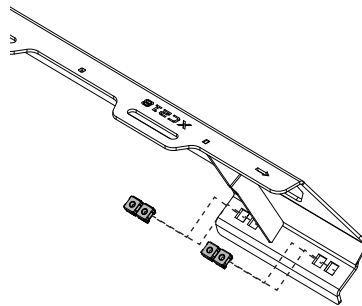

3.

Fit rubber tape to the inside of the inner clamp.

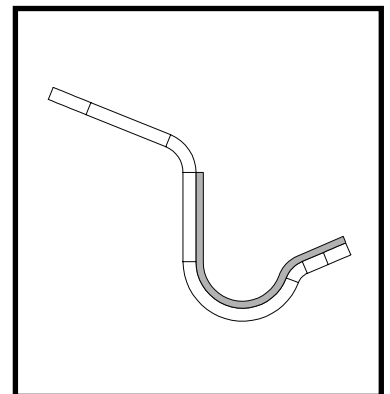
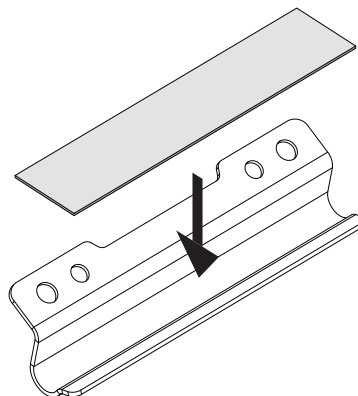

4.

Turn the Summit platform upside down, on a clear surface. Slide 2x T-bolts in the 1st, 3rd, 4th and 6th plan. Move a bolt to either end of the plank.

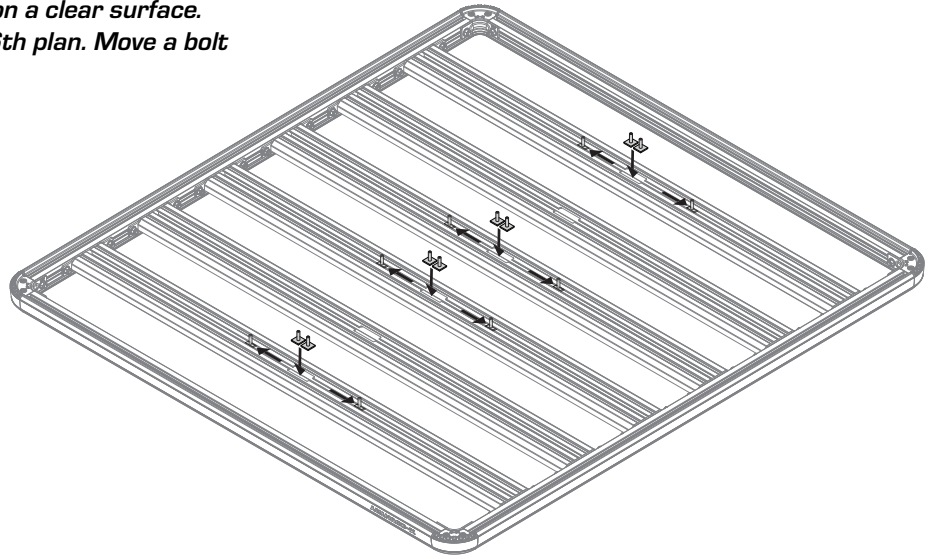

5.

Fit the wind fairing to the front of the Summit Platform.

Note: Hardware for this step found in Razor Platform kit.

Slide 4x M8 x 16mm hex bolts into the channel of the front extrusion.

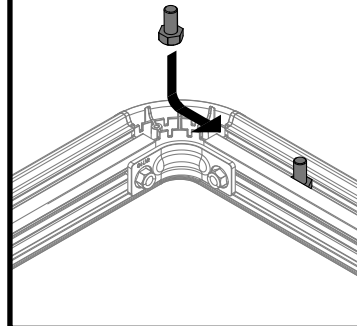

Place the fairing into place over the hex bolts installed previous. Centre the fairing and tighten in place with flanged nuts.

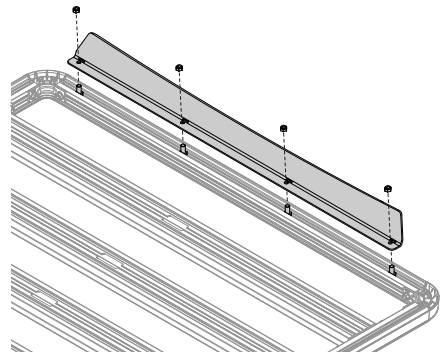

TOOL • Socket wrench and set

6.

Install foam 3M pads on the 2nd and 5th mounting point on top of the Razor. Trim to shape.

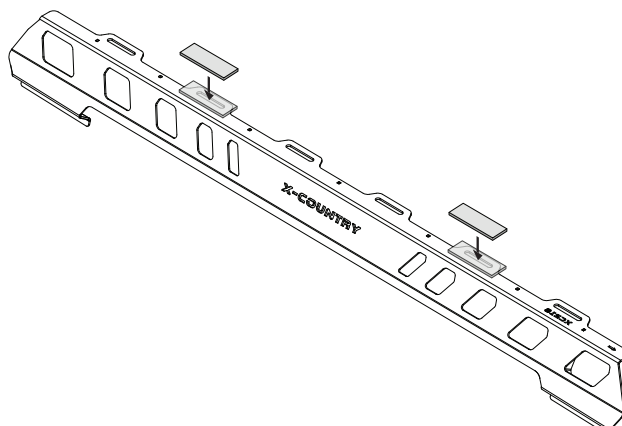

Trim the pads to the contour of the Razor.

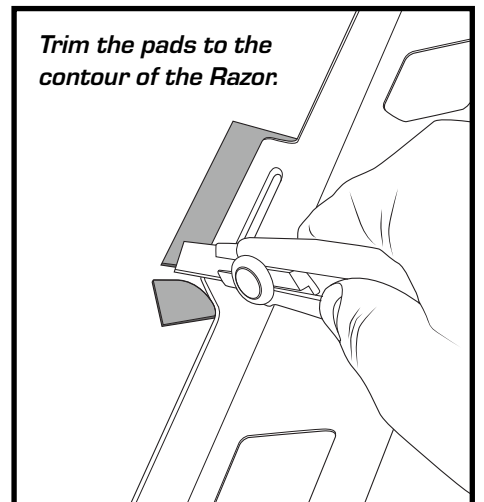

TOOL • Knife

X-COUNTRY

PAGE 5 of 7

7.

Fit the Razor in place using a plastic washer and M8 flanged nut. Finger tighten only at this stage.

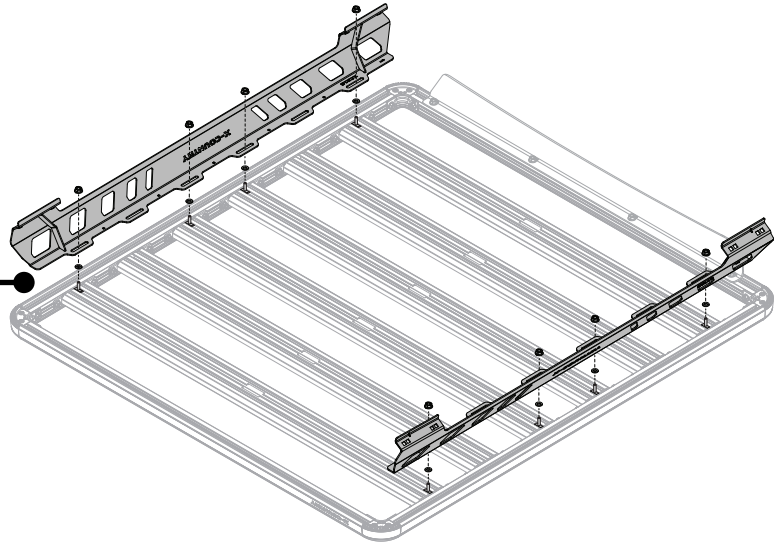
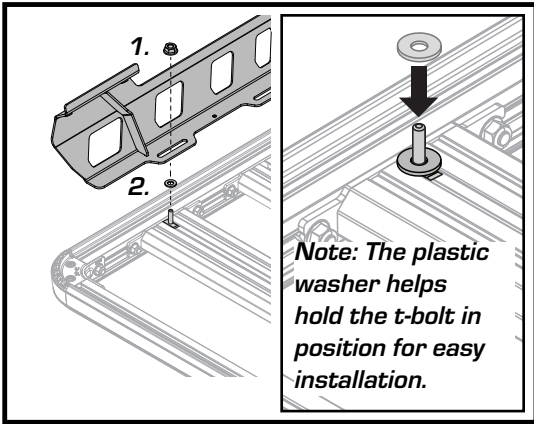

8.

Using assistance, lift the assembly onto the roof of the vehicle. Ensure both Razor assemblies are positioned evenly.

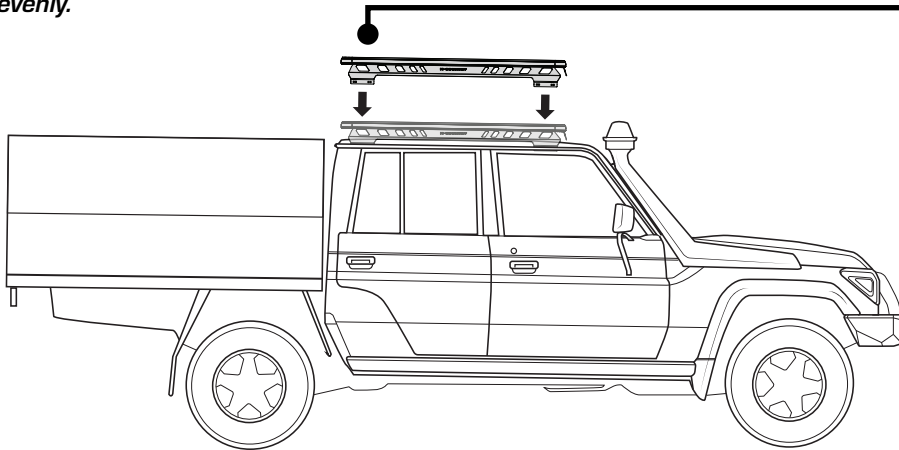

Position the rear of the Razor foot, 90-100mm from the rear of the cab. Tighten M8 hardware.

90-100mm

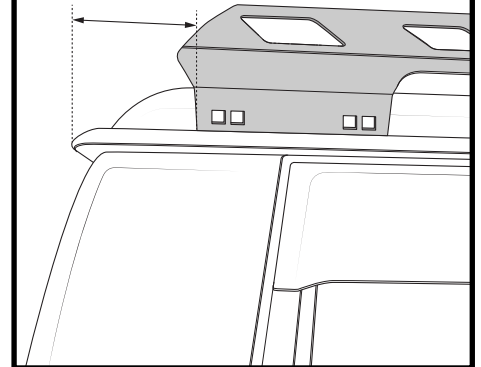

9.

A) Using the M6 hardware provided, fix the bracket to the inner hole positions front and rear.

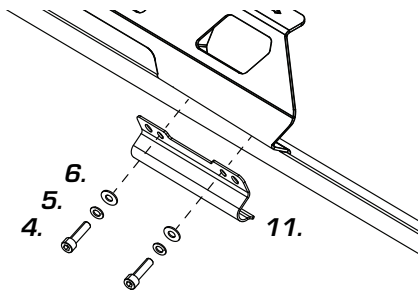

Ensure the thread correctly aligns with the cage nut. It should be easy to wind up bolt without tension. If it gets hard remove and start again until threads align.

X-COUNTRY

PAGE 6 of 7

B) Fix the outer clamp into the outer holes of the Razors as shown, both front and rear.

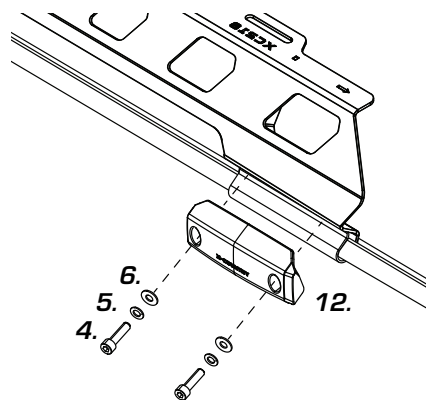

Front view:

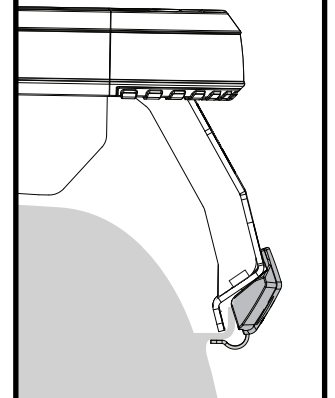

Check all fixtures are secure before use.

Ensure there is a 6-10mm gap between fairing and roof of vehicle. Adjust by loosening Summit and sliding backward.

